

Swing frame with Bird's Nest

Device line Rundholz











Article 27840

Swing frame with bird's nest made of multi-glued pine, pressure impregnated, stainless steel suspension device for two seats, steel tube and corner connectors hot-dip galvanised, with Bird's Nest Huck ø 125 cm, blue rope ring, incl. steel foot brackets for minimum installation depth 50 cm.



CHF 5'010.-

(excl. VAT)

 Age group	3+
 Device dimensions	625 x 219 x 271 cm
 Space required	795 x 625 cm
 min. impact surface	41.85 m ²
 Fall height	146 cm
 Heaviest element	35 kg
 Biggest element	320 x 38 x 29 cm
 Foundations	6
 Concrete	1.1 m ³
 Assembly time	2 h
 Installers	2

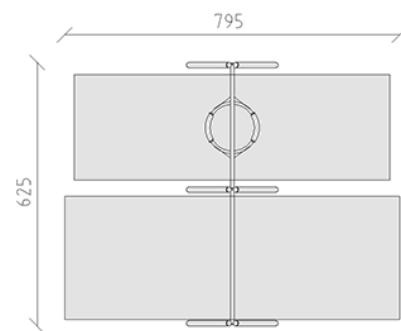

buerli
Center of play